

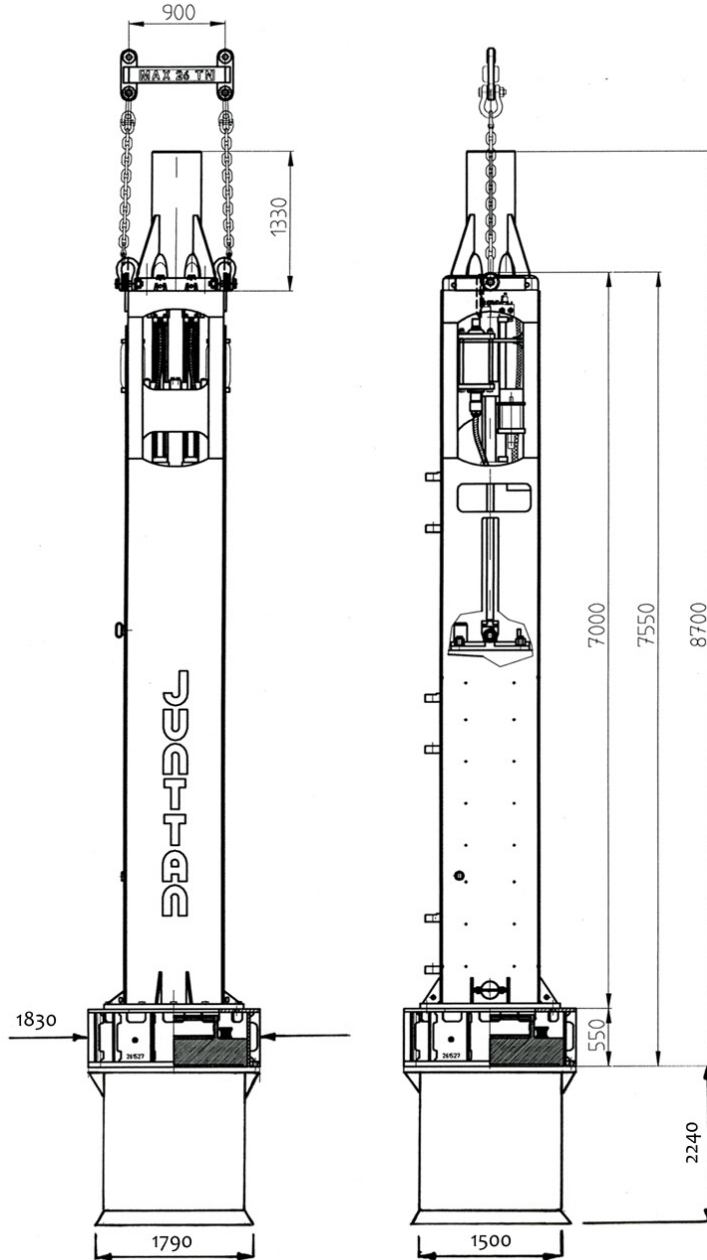

PILEQUIP AUSTRALIA PTY LTD
 ABN 72 003 477 898
 39 Chapman Road, Vineyard, NSW
 PO Box 976
 WINDSOR NSW 2756
 Tel: 61 (2) 9838 3144
 Fax: 61 (2) 9838 3150
 Email: info@pilequip.com.au
 Website: www.pilequip.com.au

Junttan HHK 14A



SPECIFICATIONS:

	<u>14A</u>	
Ram Block Mass:	14,000	kg
Maximum drop height:	1,200	mm
Maximum impact energy:	168	k.Nm
Blow rate at maximum stroke:	30	bpm
Operating hydraulic pressure:	190	bar
Total hammer weight:	29,200	kg

MC904P Piling Cushion: 750mm Ø x 200mm
 Rebound Ring (1-piece): Ø 1,010 / 850 x 105mm

Sleeves / Attachments:

*Pile sleeve : 1,500mm I.D:
 - Length: 2,240 mm
 - Weight: 2,600 kg

*Energy Measuring Device

Power Pack:

- Type: 15BCU JPack
 - Dimensions (l * w * h): 3.73 * 1.31 * 2.06 m
 - Weight (c/w fuels, oils): 5,700 kg