

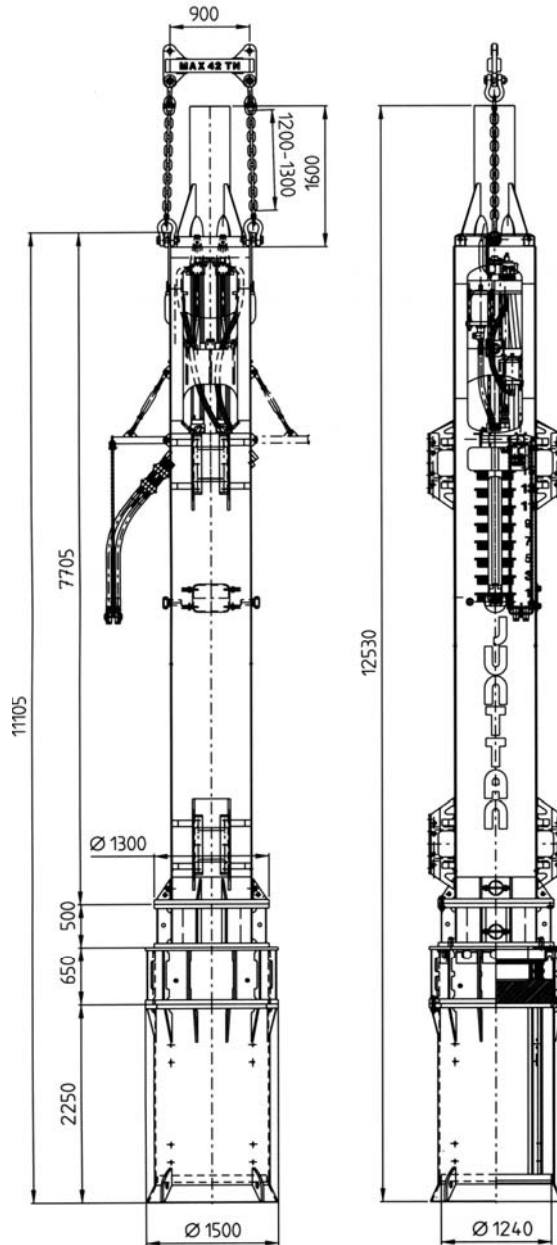

PILEQUIP AUSTRALIA PTY LTD
 ABN 72 003 477 898
 39 Chapman Road, Vineyard, NSW
 PO Box 976
 WINDSOR NSW 2756
 Tel: +61 (0) 2 9838 3144
 Fax: +61 (0) 2 9838 3150
 Email: info@pilequip.com.au
 Website: www.pilequip.com.au

Junttan HHK 14 / 16S



SPECIFICATIONS:

	14S	16S	
Ram Block Mass:	14,000	16,000	kg
Maximum drop height:	1,500		mm
Maximum impact energy:	206	235	kN.m
Blow rate at maximum stroke:	30		bpm
Operating hydraulic pressure:	210	230	bar
Total Hammer weight:	25,900	28,600	kg
MC904P Piling Cushion:	750mm Ø * 200mm		
Rebound Ring (2-piece):	Ø 1,078 / 850 * 100		mm

Sleeves / Attachments:

*Pile Sleeve : 1,240mm I.D:		
- Length:	2,260	mm
- Weight:	1,650	kg
*Flying Leader:		
*Energy Measuring Device:		

Power Pack:

- Type:	15ccu JPack	
- Dimensions (l * w * h):	3.90 * 1.72 * 2.25	m
- Weight (c/w fuels, oils):	7,400	kg