

SPEC SHEET

ICE 1200 Power Pack



INTERNATIONAL CONSTRUCTION EQUIPMENT

M1200RF002 / 0608

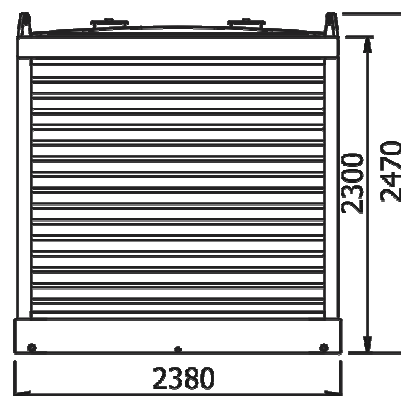
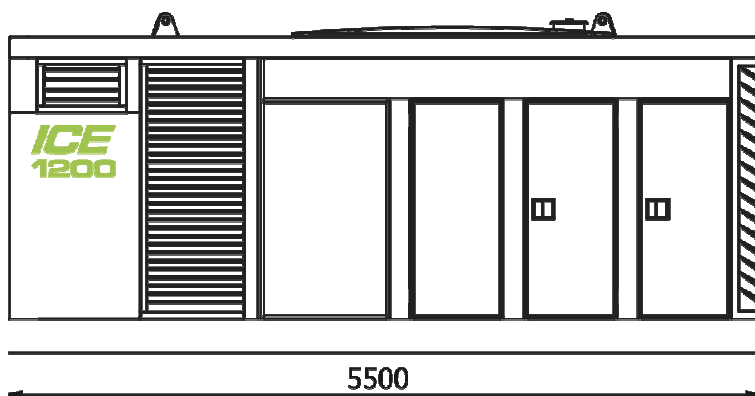
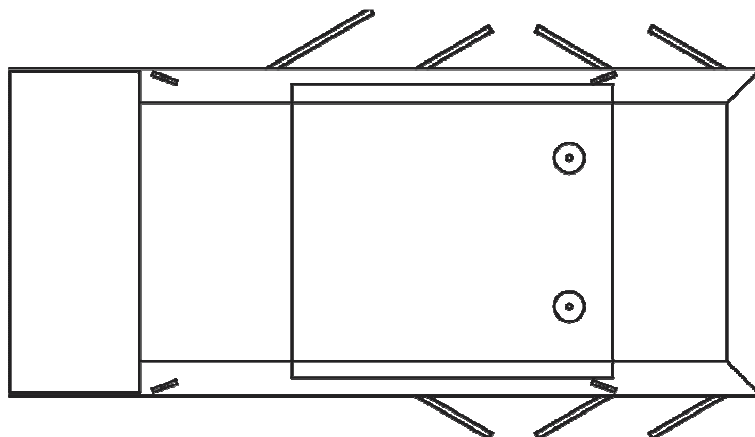

Note: Dimensions and weight subject to change

SEPCIFICATIONS	1 200RF002	
Diesel engine	Caterpillar C15 ACERT	
Max. theoretical power	806/1095	kW/HP (DIN)
Max. Frequency	2100	rpm
Max. working pressure	350	bar
Hydraulic pumps	2x Parker PVplus180 2x Parker PVplus140	
Max. oil flow	1345	L/min
Oil flow @ 350 bar	1200	L/min
Diesel oil	1700	L
Hydraulic oil	1200	L
Weight (±)	15000	kg

SPEC SHEET ICE 1200 Power Pack



INTERNATIONAL CONSTRUCTION EQUIPMENT

TECHNISCHE DATEN	1 200RF002	
Diesel Motor	Caterpillar C15 ACERT	
Max. theoretische Leistung	806/1095	kW/PS (DIN)
Max. Drehzahl	2100	UPM
Max. Betriebsdruck	350	bar
Hydraulische Pumpen	2x Parker PVplus180 2x Parker PVplus140	
Max. Fördermenge	1345	L/min
Fördermenge bei 350 bar	1200	L/min
Diesel Öl	1700	L
Hydraulische Öl	1200	L
Gewicht (±)	15000	Kg

SPÉCIFICATIONS	1 200RF002	
Moteur diesel	Caterpillar C15 ACERT	
Puissance théorique max.	806/1095	kW/CV (DIN)
Max. Fréquence	2100	rpm
Pression de travail max.	350	bar
Pompes hydrauliques	2x Parker PVplus180 2x Parker PVplus140	
Débit d'huile max.	1345	L/min
Débit d'huile à 350 bar	1200	
Huile Diesel	1700	L
Huile hydraulique	1200	L
Poids (±)	15000	kg

SPECIFICATIES	1 200RF0002	
Diesel motor	Caterpillar C15 ACERT	
Max. theoretische vermogen	806/1095	kW/PK(DIN)
Max. toerental	2100	rpm
Max. werkdruk	350	bar
Hydraulische pompen	2x Parker PVplus180 2x Parker PVplus140	
Max. olie doorstroming	1345	L/min
Olie doorstroming bij 350 bar	1200	
Diesel olie	1700	L
Hydraulische olie	1200	L
Gewicht (±)	15000	kg